

Board Of Selectmen

Meeting Minutes for May 13, 2024

Call to order

6:00 call the meeting to order.

Roll Call

Present Chairman, Verne Leach, present Member, Ed Munch. present Member, Doug Haskins

Also attending:

Bruce Cullett Chief of Police, Justin Russell Highway Superintendent, James Kenney Historical Commission and Michael Hunt

Recording status

Verne Leach is recording for personal reasons under exemption E pledge allegiance to the flag.

Pledge allegiance to the flag

(Everybody)

Review and approve board of select meeting minutes for 5/6/24

(Haskins) TA said bid opening for August Smith and Curtin. The bid was awarded to All Star paving at 47760 and that's not right

(Leach) I make a motion to approve May 6 2024 minutes pending changes, Ed Munch seconds, All in favor 3-0

Update from departments

Highway Department

(Russell) The only thing I have at some point this week I'll be meeting with mass steel Team Palmer about the repairs they need to do they had set out a schedule about doing rumble strips and all the line paint and everything else, but I don't know if that schedule is set in stone wait until we discuss the repairs that need to be done with the drains and everything. Yeah, I was surprised after I talked to you on desk about Monday night. And on Wednesday, they freaking started.

(Russell) The only thing I just wanted to mention at the transfer station, we can't take compressed gas cylinders and Acetylene bottle down there right now if they take the valves out, then they can throw them in the dumpster. Other than that, the only ones we can accept are like the little Coleman Propane bottles, that's it. OK, that big 100 LB bottle last year I got here is to take it for us.

(Munch) That's been sitting there for three weeks now I think, I accepted it because I had no idea what to do with it. And I said set it on the edge and then we'll do something with it.

(Russell) I'll probably have to get the valve out of it. They're a pain in the neck to get out if they take the valves out, that's about all I have will be working on Pierce Rd. pretty much.

(Leach) Speaking as a resident.

Any idea when you're going to start on the drain in front of my house because I'm having the driveway done and I don't want it cut up. (Russell) Well, I won't be working anywhere near your driveway (Leach) because they're replacing the culvert and everything.

(Russell) We will not be working anywhere near there. I mean, once it's dry enough we will try to. But like I said, it's not going to be dry until Paul does his culvert and gets that water to drain out.

(Leach) Which will be done the same time as my driveway. (Russell) That'll won't be until I get caught up with everything else we need to do. I mean that drains it's been cracked and broke for a long time it's off the road. It's not endangering anybody driving in to it or anything but we gotta finish. Pierce Rd. we have \$40,000 of material sitting there I can shape it up from there. That'd be the better thing.

(Haskins) How far are you going down Peirce road (Russell) As far as we can wherever we run out of material yeah, we were down here all day Friday. Today. Yeah, some areas need a lot of material.

(Haskins) I drove down to where the road splits off and turned around there they told me that was even worse at the first bridge and so Riverbed down there.

(Leach) So how far off the center of the road does the town own? (Russell) 143 is about 100 foot right away, so it's about 50 feet both ways. (Leach) So the culvert is 25 feet off the road, and it's not the town's responsibility.

(Russell) No driveway culverts are the home owners response I've gone through this with multiple residents in town. You have to get it. If you build a new house, you got to pay for a permit and put your own culvert in the town doesn't \$500 apiece. We don't have money to replace people's culverts if we want them. We gotta do everybody that asks. And if there's no way we can afford that.

(Leach) So I'm asking just to be clear

Boston Post Cane

(Kenney) There are a couple of certificates that need to be signed by this, you recall sunny Russell birth recipient after he passed away, we made an attempt to get in touch with Julia groat who The Town Clerk explained, was at the time, the current oldest resident and she has since passed, but we thought it would be sensible to get her family certificate and the current hold. This resident just accepted the honor and that's Stuart Sergeant, i spoke to his wife this morning. I had asked her when we spoke a week or so ago if she'd be willing to, or if he'd be willing to. Her family member come to the annual town meeting they talked it over. She called me this morning and said that nobody's available and Stu isn't in the condition to come up to the meeting himself.

So I told him we'll make a brief announcement, explain to the town that somebody is now a new recipient and we'll make sure the family gets the certificate. And as selectman Munch mentioned, I just took the plaques, the individual little brass plaques off of the large display, and we'll get those engraved in the next couple of days.

Selectman Leach makes a motion to sign a certificate of recognition for the Boston Post cane for Julia Groat and Stu Sergeant.

Selectman Munch seconds, all in favor, 3-0

(Russell) Jim Jones trophies on Melville St. in Pittsfield.

(Haskins) If he doesn't do it, Dana's got a guy that he's going to do a sign for me for the ball field. He can do laser and he's got laser. Plus he can do a router and so I can.

(Haskins) I'm going to try to schedule a meeting for Friday for Parks and Rec. to see if we can reorganize and see what the park wants to buy, we have money to spend on, Justin I'm gonna have to get with you because I want to put a basketball court in down there. If you can see where the stakes are, it's going to be in that area there. But I want to make sure that we got. I don't interfere any drainage. I'm going to build it up so its not going to be parking lot level. I'm probably going to keep it like the same grade as the pavilion Is that where the stakes are out from the pavilion? That's where all the water drains right now for a parking lot.

(Russell) I saw the stakes, but I don't think they look good.

(Haskins) Even if I have to, when I have somebody in there take it out, we dig a trench down through and run some stone around the edge and kind of swell. Yeah, and go around it. It's pretty much up in the winter. That's where I try to keep a path through the snow because the water drains worst.

Discussion, interview and possible appoint Michael Hunt as a police officer

Welcome, Michael, as I mentioned last week Michael has expressed interest in becoming a Peru Police Officer that's been posted for over two years, he now lives in town as of last fall.

(Cullett) And as I think everybody here knows him, he worked for the department from late 2012 to 2016 when he left to become full time officer in Becket, so I think he would be an asset to the town I very much would like a officer living in town and I would request that the Board of Selectmen appointment him

(Leach) How many hours do you put on down in Becket, 40 full time?

(Hunt) Not 40 hours a week.

(Leach) And you would be available for the one weekend day one weekend a month.

(Hunt) My schedule is very flexible, yes.

(Haskins) My only question to you, Bruce, is, is there any going to be any conflict between the chief and working part time up here I know that it was a policy of the Beckett Police Department that they would not allowed to work for any other agency, but he's been approached like approached him and he's given permission. Can we just get that? Can we get that written from them so we can just file it? That's all. I don't have a problem with that otherwise. Yeah, we're going to have to have it only because we had an issue years ago when I think it was with Barnaby in Windsor.

(Cullett) We're going to have to establish a memorandum of Understanding anyway because there'll be some overlap of equipment and in nature so that we're both on the same page, so we're working

those details. (Leach) Ed any questions, Doug anymore questions. Do you have any questions for us? (Hunt) No, Sir.

(Leach) I make a motion to appoint Michael Hunt as a police officer,(Munch) I second that. All in favor 3-0

(Haskins I just, just as long as Bruce gets a letter from our Becket. That's all. No problem.

(Leach) And if you contact the Town Clerk. She'll swear you in

Discussion on FY25 budget / Annual town meeting

(LEACH) The TA Gave you a copy of the warrant. Two of the articles was removed because they were not bylaws, therefore they do not have to be voted on at a Town Meeting. The Cemetery Commission regulations have to be voted on by the Select Board and the well regulations have to be voted on by the Board of Health (Leach) Are we good with the changes? (MUNCH) As in what? What were the changes? Because that's the only way we're going to. She had to fix all the numbers. OK, well, I don't have the numbers.(Leach) FY25 Warrant has the changes on all of them.

There was a few wage accounts that she had to changed and she did, She had to take out the two articles. (Munch) Yeah, you know, once again, you don't have the numbers in front of you. So assuming that these numbers are correct. (Haskins) Well, I remember a couple and those changes were made.

(Leach) If you're both good with it, I make a motion to sign the warrant for the Annual Town Meeting for 2024, as is. (Haskins) Second, all right. All in favor, 3-0

Discussion and possible vote on public hearing for Eversource.

(Leach) They would like to set up a hearing, Eversource wood for South Road and for strong Rd. The reason to extend faculties and provide power to homeowners. Are you aware of this, Justin?

(Russell) I am, but they haven't contacted me, you know, they got poll locations. My fault. But that's probably part of it. A lot of poles on South Road. Well, right now the power stops there with Cornell Lane. (Leach) Yeah, we got to have a public hearing. All right. So I motion to vote to have a public hearing for Eversource, (Munch) second, all in favor. 3-0 (LEACH) we will put this on hold.

Public input

N/A

Review approve accounts payable. Treasury warrant payroll warrant

(Leach) I'd like to motion to recess the meeting at 6:49 until the payrolls ready Haskins seconds, All in favor, 2-0. Selectman Munch already left the room for Payroll

Call the Meeting back to order at 6:50

Roll Call Present Verne Leach, present Ed munch. present Doug Haskins

Payroll

Payroll warrant

Discusstion on next weeks agenda, Mass Works Grant, Eversource Hearing and reappointment papers.

(Leach) I make a motion to adjourn the meeting at 6:55, (Munch) I second, All in favor, 3-0

Meeting adjourn.

A list of articles used in the meeting:

May 6 2024 Meeting Minutes

Boston Post Cane Certificate of Recognition (2)

Resume

2024 Annual Town Meeting Warrant

Eversource Public Hearing Request form

Vender Warrant

Payroll Warrant

Respectfully submitted,

By Verne Leach

 _____ Date 5-20-24

Verne Leach, Chairman

 _____

Edward Munch, Member

 _____

Douglas Haskins, Member

RECEIVED
MAY 21 2024

TOWN CLERK
TOWN OF PERU

CERTIFICATE OF RECOGNITION

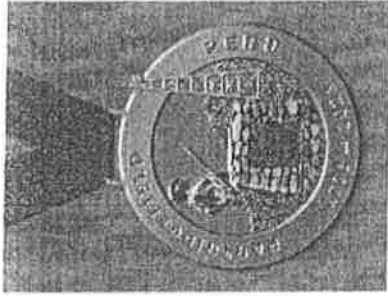

Be It Known that the Peru Selectboard does hereby Extend its Congratulations to

Julia Groat

It is with great pleasure that the Town of Peru Selectboard presents this citation to you for being the oldest resident at the age of 89 in the Town of Peru, Massachusetts. Your name will be included on the plaque that accompanies the Boston Post Cane that is currently on display in the Peru Town Hall.

In recognition thereof we have signed our names officially and caused the seal of the Town of Peru to be affixed.

Verne Leach, Chair

Ed Munch

Doug Haskins

Kim Leach, Town Clerk

CERTIFICATE OF RECOGNITION

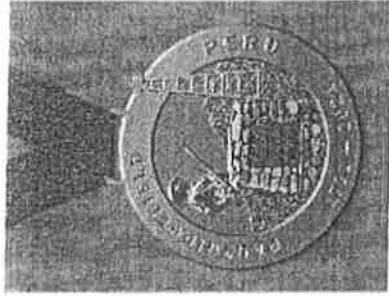

Be It Known that the Peru Selectboard does hereby Extend its Congratulations to

Stuart Sargent

It is with great pleasure that the Town of Peru Selectboard presents this citation to you for being the oldest resident at the age of 87 in the Town of Peru, Massachusetts. Your name will be included on the plaque that accompanies the Boston Post Cane that is currently on display in the Peru Town Hall.

In recognition thereof we have signed our names officially and caused the seal of the Town of Peru to be affixed this 1st Day of June in the year Two Thousand and Twenty-Four.

Verne Leach, Chair

Ed Munch

Doug Haskins

Kim Leach, Town Clerk

Michael Hunt

Mhunt0869@yahoo.com • 413-344-5129

EDUCATION

MPTC Reserve/Intermittent Police Academy Group D	2011
Western Mass Regional Full Time Police Academy 55 th ROC	2016
AXON Certified TASER Instructor	2014
MPTC Certified Firearms Instructor	2016

PROFESSIONAL EXPERIENCE

Windsor Police Department <i>Part Time Police Officer</i>	2011-2012
Hinsdale Police Department <i>Part Time Police Officer</i>	2012-2013
Peru Police Department <i>Part Time Police Officer</i>	2012-2016
Becket Police Department <i>Part Time Police Officer 2012-2016, Full Time Police Officer 2016-2023, Full Time Sergeant 2023- Present</i>	2012- Present

**ORDER OF BUSINESS
COMMONWEALTH OF MASSACHUSETTS
Berkshire, ss**

To either of the Constables of the Town of Peru, in said County.

GREETINGS:

In the name of the Commonwealth of Massachusetts, you are hereby required to notify and warn the inhabitants of the Town of Peru, qualified to vote in Town affairs, to meet in the Town Fire Station, 11 East Main Road Peru, MA on Saturday, June 1, 2024, at 6:00 PM for the Annual Town Meeting, then and there to take action on the following articles, namely:

Article 1: To choose a Moderator for the Annual Town Meeting if the elected Moderator is absent.

Article 2: To see if the Town will vote to accept the reports of the several Town Officers.

Article 3: To see if the Town of Peru will vote to approve the Central Berkshire Regional School District Amended Regional Agreement as presented by the School Committee, which will be on file at the Peru Town Clerk's Office, Superintendent of Schools Office and the Peru Public Library, or take any other action relative thereto:

Article 4: To see if the Town will vote to raise and appropriate the following sums of money for the Central Berkshire Regional School District FY25 Assessment, or to take any other action relative thereto:

Net Operating Assessment	943,938.00
Capital Assessment	<u>117,707.00</u>
Total Town of Peru Assessment	\$1,061,645.00

Board of Selectmen and Finance Committee in support of this article.

Article 5: To see if the Town will vote to fix salaries of all elected officers as provided by Section 108 of Chapter 41 of M.G. L., for FY25 or take any other action relative thereto:

Selectboard

Member	\$ 3,682.25
Member	3,682.25
Member	3,682.25

Town Clerk 10,609.00
Board of Selectmen and Finance Committee in support of this article.

Article 6: To see if the Town will vote to fix salaries of the following appointed officers for FY25, or to take any other action relative thereto:

Assessors'	
Lead Assessor	19,281.60
Assessor #1	3,775.13
Assessor	2,575.00
Treasurer	13,112.72
Tax Collector	13,112.72
Accounting Services	31,800.00
Animal Control Officer	1,968.33
Police Chief	69,525.00
Inspector of Animals	978.50
Veterans' Agent	515.00
Council on Aging Director	1,236.00
Fire Chief	2,600.75
Cemetery Sexton	515.00
Town Auditor	1.00

Board of Selectmen and Finance Committee in support of this article.

Article 7: To see if the Town will vote to raise and appropriate the following sums of money for the following accounts for FY25, or take any other action relative thereto:

Assessors' Salaries	\$ 25,631.73
Selectmen's Salary	11,046.75
Tax Collector's Salary	13,112.72
Town Clerk's Salary	10,609.00
Treasurer's Salary	13,112.72
Accounting Services	31,800.00
Assessing Services	25,000.00
Animal Control Officer's Salary	1,968.33
Inspector of Animals Salary	978.50
Veterans' Agent Salary	515.00
Council on Aging Director	1,236.00
Fire Chief	2,600.50
Police Chief	69,525.00
Cemetery Sexton Salary	515.00
Town Auditor	1.00

Board of Selectmen and Finance Committee in support of this article.

Article 8: To see if the Town will vote to raise and appropriate the following sums of money for the following wage accounts for FY25, or to take any other action relative thereto:

Administrative Assistant	\$ 5,000.00
Elections & Registrar's Account	5,850.00
Assistant Town Clerk	2,811.90
Compactor Attendants	8,188.50
Town Administrator's Salary	\$35,000.00

Board of Selectmen and Finance Committee in support of this article.

Article 9: To see if the Town will vote to raise and appropriate the following sums of money for the following accounts for FY25, or to take any other action relative thereto:

Assessors' Expense	\$ 1,000.00
Bank Service Expense	100.00
Animal Control Officer's Expense	1,000.00
Selectmen & Other Expenses	2,000.00
Tax Collector's Expenses	1,500.00
Tax Collector's Tax Taking Charges	1,500.00
Town Clerk's Expense	2,200.00
Town Report Expense	2,000.00
Treasurer/Accounting Expense	1,500.00
Treasurer Tax Title Expense	6,000.00
Board of Appeals Expense	100.00
U.S. Postal Expense	4,000.00
Health Department Expense	16,000.00

Board of Selectmen and Finance Committee support this article.

Article 10: To see if the Town will vote to raise and appropriate the following sums of money for the following accounts for FY25, or to take any other action relative thereto:

Assessors' Annual Computer Support	\$ 2,400.00
Computer Supplies & Maintenance IT	24,000.00
Treas./Acct. Annual Computer Support	13,941.87
Tax Collector's Annual Computer Support	11,411.17
Assessors' Tax Map Maintenance	1,600.00
Continuing Education	3,000.00
Office Supplies	2,000.00
Assessor Utility Appraisal	3,500.00

Board of Selectmen and Finance Committee support this article.

Article 11: To see if the Town will vote to raise and appropriate the following sums of money for the following accounts for FY25, or to take any other action relative thereto:

Conservation Commission Expense	\$ 400.00
Interest on Loans	1,000.00
Legal Expense	9,900.00
Officers' Mileage	1,500.00

Board of Selectmen and Finance Committee Support this article.

Article 12: To see if the Town will vote to raise and appropriate the following sums of money for the following accounts for FY25, or to take any other action relative thereto:

Elderly Outreach	\$ 650.00
Council on Aging Expense	1,000.00
Veterans Service	6,000.00

Board of Selectmen and Finance Committee support this article.

Article 13: To see if the Town will vote to raise and appropriate the following sums of money for the following accounts for FY25, or to take any other action relative thereto:

Medicare -- Town Share	\$ 6,300.00
Health Ins/Life & Dental	142,450.56
Town Insurance - All	43,559.00
Mass. Unemployment Insurance	600.00
CHUBB Insurance	8,300.00

Board of Selectmen and Finance Committee support this article.

Article 14: To see if the Town will vote to raise and appropriate the following sums of money for the following accounts for FY25, or to take any other action relative thereto:

Partridge Field Playground Trust	\$ 1,500.00
Peru Library	21,243.00
Mowing: Cemeteries, Town Hall, Town Park and Town Green:	6,500.00

Board of Selectmen and Finance Committee support this article.

Article 15: To see if the Town will vote to raise and appropriate the following sums of money for the following accounts for FY25, or to take any other action relative thereto:

Town Buildings' Maintenance	\$ 15,000.00
Utilities – Electric	12,500.00
Utilities – Heating	19,000.00
Utilities - Telephone	1,500.00
Internet Communication Lines	7,000.00
Town Website Design, Hosting, & Support	1,930.00

Town Hall Janitorial Services	4,900.00
Cemetery Expense	500.00

Board of Selectmen and Finance Committee support this article.

Article 16: To see if the Town will vote to raise and appropriate the following sums of money for the following accounts for FY25 or to take any other action relative thereto:

Compactor	\$ 38,000.00
Northern Berkshire Solid Waste District	3,178.48

Board of Selectmen and Finance Committee support this article.

Article 17: To see if the Town will vote to raise and appropriate the following sums of money for the following accounts for FY25, or to take any other action relative thereto:

Berk. County Sheriffs Dispatching	\$ 11,792.36
Berk. County Reg. Planning Comm.	710.30
Berk. County Retirement Assessment	62,960.00
Hinsdale Ambulance	3,000.00
Town Fire Station Mortgage Payment	14,338.13
Police Wages	39,000.00
Police Expenses	7,450.00
Police Cruiser Maintenance	3,500.00
Police Continuing Education	3,000.00

Board of Selectmen and Finance Committee support this article.

Article 18: To see if the Town will vote to raise and appropriate the following sums of money for the following accounts for FY25, or to take any other action relative thereto:

Peru Volunteer Fire Department Operating Expenses	\$ 25,000.00
Peru Volunteer Fire Department Insurances	6,000.00
Peru Volunteer Fire Department Building Maintenance	2,000.00

Board of Selectmen and Finance Committee support this article.

Article 19: To see if the Town will vote to raise and appropriate the following sums of money for the following accounts for FY25, or to take any other action relative thereto:

Gas & Fuel Account	\$ 33,000.00
Maintain Hard Surface Roads	28,000.00
Material, Gravel Roads	25,000.00
Road Machinery Maintenance	25,000.00
Snow Roads, Private	500.00
Snow Roads, Public	90,000.00
Town Highways & Bridges	20,000.00

Town Highway Garage Mortgage Payment	12,020.00
Highway Employee Wage Acct.	110,210.00
Highway Superintendent Salary	77,250.00
Highway Department Uniforms	3,700.00
Tree Removal	25,000.00
Temporary Summer Help	8,000.00

Board of Selectmen and Finance Committee support this article.

Article 20: To see if the Town will vote to raise and appropriate the following sums of money for the vocational education and transportation accounts for FY25, or take any other action relative thereto:

Vocational School Tuition	\$208,470.00
Vocational School Transportation	43,027.20

Board of Selectmen and Finance Committee support this article.

Article 21: To see if the Town will vote to transfer from **Free Cash** the sum of Fifty Thousand Dollars and Zero cents (\$50,000.00) to lower the tax rate or take any other action relative thereto. Board of Selectmen and Finance Committee support this article.

Article 22: To see if the Town will vote to transfer from **Free Cash** the sum of Fifty Thousand Dollars and Zero Cents (\$50,000.00) for a Town Hall Assessment Study, or to take any other action relative thereto.

Board of Selectmen and Finance Committee support this article.

Article 23: To see if the Town will vote to transfer from **Free Cash** the sum Thirty One Thousand Five Hundred Dollars and Zero Cents (\$31,500.00) to Communication Equipment for the Police Department, or to take any other action relative thereto.

Board of Selectmen and Finance Committee support this article.

Article 24: To see if the Town will transfer from **Free Cash** the sum of Seventeen Thousand One Hundred Fifty Dollars and Thirty Cents (\$17,150.30) to purchase the following items for the Highway Department: Sandblast the 2009 International \$7,958.00, Sandblast the 2016 Ford 550 \$6,992.30, and a plasma tool cutter \$2,200.00, including all costs incidental or related, or to take any other action relative thereto.

Board of Selectmen and Finance Committee support this article.

Article 25: To see if the Town will transfer from **Free Cash** the sum of Fifteen Thousand Dollars and Zero Cents (\$15,000.00) to the Interest on Loans Account or take any other action relative thereto.

Board of Selectmen and Finance Committee support this article.

Article 26: To see if the Town will transfer from **Free Cash** the sum of Five Thousand Dollars and Zero Cents (\$5,000.00) for IT services, including all costs incidental or related, or take any other action relative thereto.

Board of Selectmen and Finance Committee support this article.

Article 27: To see if the Town will Transfer from **Free Cash** the sum of Five Thousand Dollars and Zero Cents (\$5,000.00) for Berkshire Regional Planning Commission to update Town Zoning bylaws or take any other action relative thereto.

Board of Selectmen and Finance Committee support this article.

Article 28: To see if the Town will vote to transfer from **Free Cash** the sum of Three Thousand One Hundred Dollars and Zero Cents (\$3,100.00) for Town Clerk Software, including all costs incidental or related, or take any other action relative thereto.

Board of Selectmen and Finance Committee support this article.

Article 29: To see if the Town will Transfer from **Free Cash** the sum of Six Thousand Five Hundred Eighty-One Dollars and Zero Cents (\$6,581.00) for the following Cemeteries: \$2,98.00 to establish boundaries at South Thompson Burial Ground, \$1,800.00 for resetting headstones at the North Cemetery, \$1,800.00 for flagpole at South Cemetery, including all costs incidental or related, or take any other action relative thereto.

Board of Selectmen and Finance Committee support this article.

Article 30: To see if the Town will vote to transfer from **Free Cash** the sum of One Thousand Five Hundred Dollars and Zero Cents (\$1,500.00) for a matching grant for a Bullet Proof Vest for the Police Department or take any other action relative thereto.

Board of Selectmen and Finance Committee support this article.

Article 31: To see if the Town will vote to transfer from **Free Cash** the sum of One Hundred Thousand Dollars and Zero Cents (\$100,000.00) to the Future Equipment Account or take any other action relative thereto.

Board of Selectmen and Finance Committee support this article.

Article 32: To see if the Town will vote to transfer from **Free Cash** the sum of Ten Thousand Dollars and Zero Cents (\$10,000.00) to the Reserve Fund for FY25 or take any other action relative thereto.

Board of Selectmen and Finance Committee support this article.

Article 33: To see if the Town will vote to appropriate from Chapter 90 funds that are, or may become, available to the Town during FY25 for Roadway Projects and Repairs, and to authorize the Treasurer to borrow such amounts in anticipation of reimbursement by the Commonwealth or take any other action relative thereto.

Article 34: To see if the Town will vote to authorize the Board of Selectmen, or other Town Departments with the approval of the Board of Selectmen, to apply for and accept grants from the

Federal Government, Commonwealth of Massachusetts or any other source, and to expend the same for purposes received without further appropriation, or to take any other action relative thereto.

ATTEST:

This is a true copy.

Kim Leach

Kim Leach

Town Clerk

Certified: May 14th, 2024

You are directed to serve this warrant with your doing thereon to the Town Clerk or the Board of Selectmen at the time and place of said meeting.

Given under our hands this _____ day of May, 2024.

BOARD OF SELECTMEN

Verne Leach
Verne Leach, Chairman

Ed Munch
Ed Munch, Member

Doug Haskins
Doug Haskins, Member

I have served this Warrant as directed above.

Places of Posting: Bulletin Board/Town Hall/Transfer Station/Library/Community Center/Website: Townofperuma.com

ATTEST:

Carole E. [Signature]
Constable

5/17/2023
Date

1:45 PM
Time

Posted: May 14, 2024



ORDER FOR SOLELY OWNED POLE LOCATIONS

By the Selectboard of Peru, Massachusetts.

Notice having been given and a public hearing held, as provided by law,
IT IS HEREBY ORDERED:

that the NSTAR ELECTRIC COMPANY DBA EVERSOURCE be and it is hereby granted a location for and permission to construct and maintain a line of poles wires and cables together with such sustaining and protecting fixtures as said Company may deem necessary, in the public way hereinafter referred to as requested in petition of said Company dated the 26th day of April, 2024.

All construction under this order shall be in accordance with the following conditions:

Poles shall be of sound timber, and reasonably straight, and shall be set substantially at the points indicated upon the plan marked 16371034 filed with and made a part of said petition. There may be attached to said poles not to exceed 18 wires and 2 cables and all of said wires and cables shall be placed at a height of not less than 18 feet from the ground.

The following is the public way along which the poles above referred to may be erected, and the number of poles which may be erected thereon under this order:

Location – South Road & South Road Ext, Peru. Install a total of seven (7) solely owned poles.
The poles are shown as red dots in sketches.

South Road:

- 1) Install pole #26/B40 approximately one hundred forty (140) feet easterly from existing p#26/41.
- 2) Install pole #26/B39 approximately one hundred sixty-five (165) feet east from proposed p#26/B40.
- 3) Install pole #26/B38 approximately one hundred eighty (180) feet east from proposed p#26/B39.
- 4) Install pole #26/B37 approximately one hundred eighty (180) feet east from proposed p#26/B38.

South Road Ext:

- 5) Install pole #33/10 approximately two hundred five (205) feet southeasterly from existing p#33/11.
- 6) Install pole #33/9 approximately two hundred five (205) feet southwesterly from proposed p#33/10.
- 7) Install pole #33/8 approximately two hundred five (205) feet southeasterly from proposed p#33/9.

Reason – Overhead Reliability Project.

Also that permission be and thereby is granted to said EVERSOURCE to lay and maintain underground laterals, cables and wires in the above or intersecting public ways for the purpose of making connections with such poles and buildings as it may desire for distribution purposes.

April 26, 2024

Verne Leach, Select Board Chair
Town of Peru
3 East Main Road
Suite #107
Peru, MA 01235

Dear Chairperson Leach,

Under the provisions of Chapter 166 of General Laws and any additions thereto or amendments thereof, a public hearing IS NECESSARY on the attached petitions. Please schedule a public hearing at your earliest convenience.

A signed original of the Order should be returned to EVERSOURCE with your approval, disapproval or comments noted thereon. A signed original should also be retained for your files. Recording of the petition is not necessary. When adopted, please forward the Orders to the Town Clerk for recording.

Town Clerk, please return signed and recorded orders to:

Joanne Fox
District Representative
EVERSOURCE
333 West St.
Pittsfield, MA 01201

NOTE: On questions pertaining to this order, please call Michael Anthony at (413) 212-7433.

Sincerely,

Joanne Fox

Joanne Fox
District Representative

Enclosures
16371034



To the Town Clerk of Peru, Massachusetts

Kindly review the attached petition for the location of pole(s), guys, wires and/or cutting/trimming in your town. A town hearing is needed. Approval and recording of the Order is required.

In addition, please fill in the attached abutter cards and mail to addressees so they will be notified of the upcoming hearing regarding this petition.

Please return one signed original copy of the Order to EVERSOURCE with your approval, disapproval or comments to:

Joanne Fox
District Representative
EVERSOURCE
333 West Street
Pittsfield, MA 01201

Please do not hesitate to call Michael Anthony at (413) 212-7433 with questions regarding pole, wires or locations.

Thank you!

Joanne Fox

Joanne Fox
District Representative
Eversource

(413) 499-9077
Ref #16371034

EVERSOURCE ENERGY

CITY: PERU

STREET: SOUTH RD

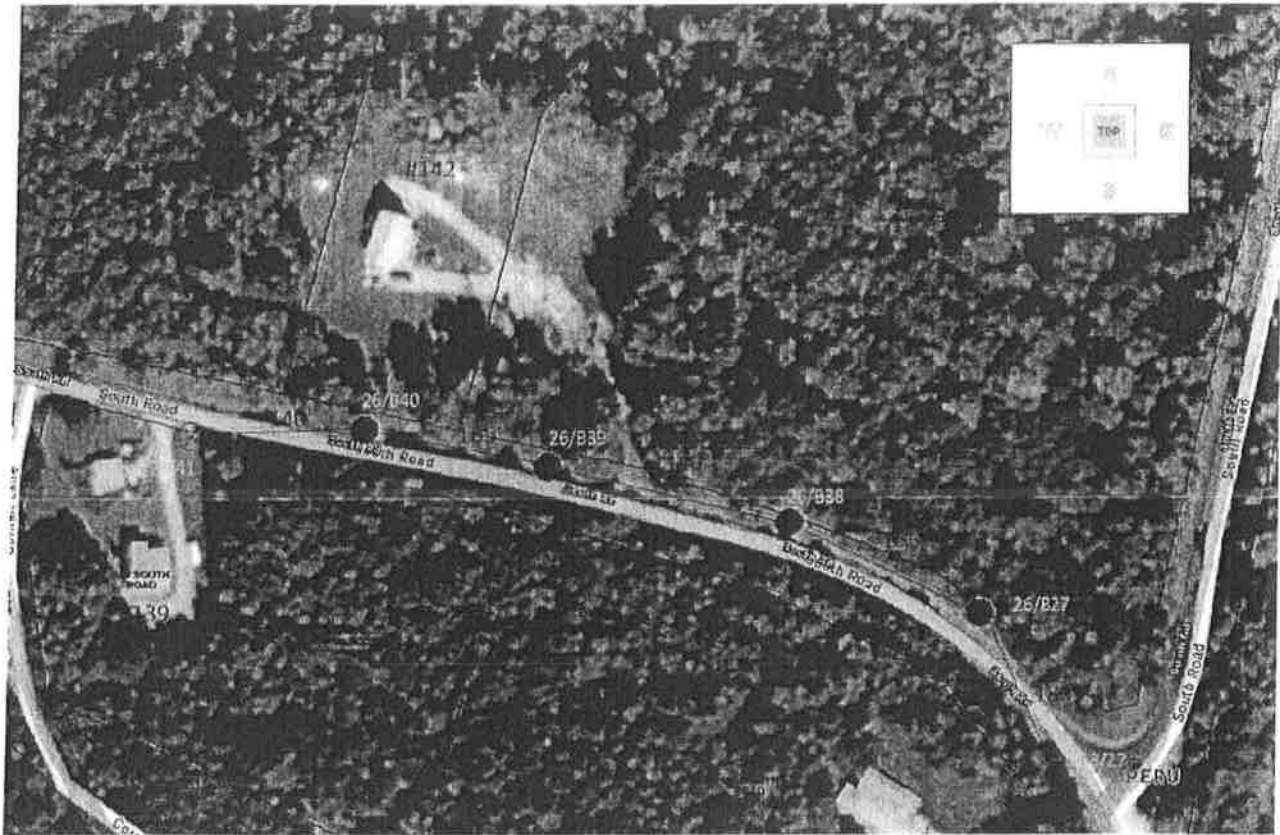

PURPOSE AND DESCRIPTION:

This project is part of an OH Reliability Improvement project. Eversource would like to change the way the overhead feeds down South Rd. Currently the OH feeds down Garnet Mtn Ln which is not plowed in the winter. We would like to continue the OH down south rd, so it connects from one side of Middlefield rd to the other. Eversource would like to set 4 new solely owned 40' class 2 poles.

LEGEND

⊗ PROPOSED JOINT POLE

● PROPOSED W.M.E.CO POLE

⊗ EXISTING JOINT POLE

○ EXISTING W.M.E.CO POLE

⊗ EXISTING FOREIGN POLE TO BE MADE JOINT

⊗ EXISTING W.M.E.CO POLE TO BE MADE JOINT

⬢ HEXHOLE

Ⓜ HANDHOLE

□ MANHOLE

■ PAD MONT TRANSFORMER

⋯ U.G. CONDUIT

—P— U.G. PRIMARY CABLE

—S— U.G. SECONDARY CABLE

DRAWN BY: MICHAEL ANTHONY

W.O.#: 16371034
W.R.#:

PETITION #:
N/A

DISTANCES ARE APPROXIMATE
NOT TO SCALE

EVERSOURCE ENERGY

CITY: PERU

STREET: SOUTH RD EXTENSION



PURPOSE AND DESCRIPTION:

This project is part of an OH Reliability Improvement project. Eversource would like to extend the pole line on South Rd Extension in an effort to increase system reliability. This gives us the ability to back feed the power from an alternate location in case of an outage. Eversource would like to set 3 new solely owned 40' class 2 poles.

LEGEND

⊗ PROPOSED JOINT POLE

● PROPOSED W.M.E.CO POLE

⊗ EXISTING JOINT POLE

○ EXISTING W.M.E.CO POLE

⊗ EXISTING FOREIGN POLE TO BE MADE JOINT

⊗ EXISTING W.M.E.CO POLE TO BE MADE JOINT

⬡ HEXHOLE

Ⓜ HANDHOLE

□ MANHOLE

■ PAD MOUNT TRANSFORMER

⋯ U.G. CONDUIT

—P— U.G. PRIMARY CABLE

—S— U.G. SECONDARY CABLE

DRAWN BY: MICHAEL ANTHONY

W.O.#: 16371034
W.R.#:

PETITION #:
N/A

DISTANCES ARE APPROXIMATE
NOT TO SCALE



ORDER FOR SOLELY OWNED POLE LOCATIONS

By the Select Board of Peru, Massachusetts.

Notice having been given and a public hearing held, as provided by law, IT IS HEREBY ORDERED:

that the NSTAR ELECTRIC COMPANY DBA EVERSOURCE be and it is hereby granted a location for and permission to construct and maintain a line of poles wires and cables together with such sustaining and protecting fixtures as said Company may deem necessary, in the public way hereinafter referred to as requested in petition of said Company dated the 3rd day of May, 2024.

All construction under this order shall be in accordance with the following conditions:

Poles shall be of sound timber, and reasonably straight, and shall be set substantially at the points indicated upon the plan marked **16741834-16747339** filed with and made a part of said petition. There may be attached to said poles not to exceed 18 wires and 2 cables and all of said wires and cables shall be placed at a height of not less than 18 feet from the ground.

The following is the public way along which the poles above referred to may be erected, and the number of poles which may be erected thereon under this order:

Location – Strong Road, Peru. Install five (5) solely owned poles:

Eversource is requesting permission to install five (5) forty-foot utility poles to be numbered 29/6 thru 29/10 with anchoring along Strong Road, extending facilities from our last existing pole 29/5 to 20 Strong Road. The poles will alternate the road approximately twenty feet from the road centerline and spaced approximately one hundred fifty to one hundred sixty (150-160) feet apart.

Reason – To extend facilities and provide power to homeowners.

Also that permission be and thereby is granted to said EVERSOURCE to lay and maintain underground laterals, cables and wires in the above or intersecting public ways for the purpose of making connections with such poles and buildings as it may desire for distribution purposes.

LEGEND

-  PROPOSED JOINT POLE
-  PROPOSED EVERSOURCE POLE
-  EXISTING JOINT POLE
-  EXISTING EVERSOURCE POLE
-  EXISTING EVERSOURCE POLE TO BE JOINT
-  EXISTING FOREIGN POLE TO BE JOINT
-  PROPOSED PAD MOUNT TRANSFORMER
-  EXISTING PAD MOUNT TRANSFORMER
-  EXISTING MANHOLE
-  UG EXISTING CONDUIT
-  UG PROPOSED CONDUIT
-  PROPOSED HANDHOLE
-  EXISTING HANDHOLE
-  ANCHOR
-  PROPOSED SILO
-  EXISTING SILO
-  HEXHOLE

PROPRIETARY INFORMATION:
 THE INFORMATION ON THIS MAP SHALL BE CONSIDERED PROPRIETARY TO EVERSOURCE AND THE USER/OWNER SHALL BE DEEMED AS ANY INFORMATION CONTAINED HEREIN IS NOT TO BE REPRODUCED, COPIED, DISSEMINATED, OR TRANSMITTED IN ANY FORM OR BY ANY MEANS, ELECTRONIC OR MECHANICAL, INCLUDING PHOTOCOPYING, RECORDING, OR BY ANY INFORMATION STORAGE AND RETRIEVAL SYSTEM, WITHOUT THE EXPRESS WRITTEN PERMISSION OF EVERSOURCE UTILITIES.

EVERSOURCE
 ENERGY

PETITION PROPOSAL
 STRONG RD
 PERU

DATE	BY	REVISION	DESCRIPTION
04/29/16	TC	1	ISSUE FOR PERMITS

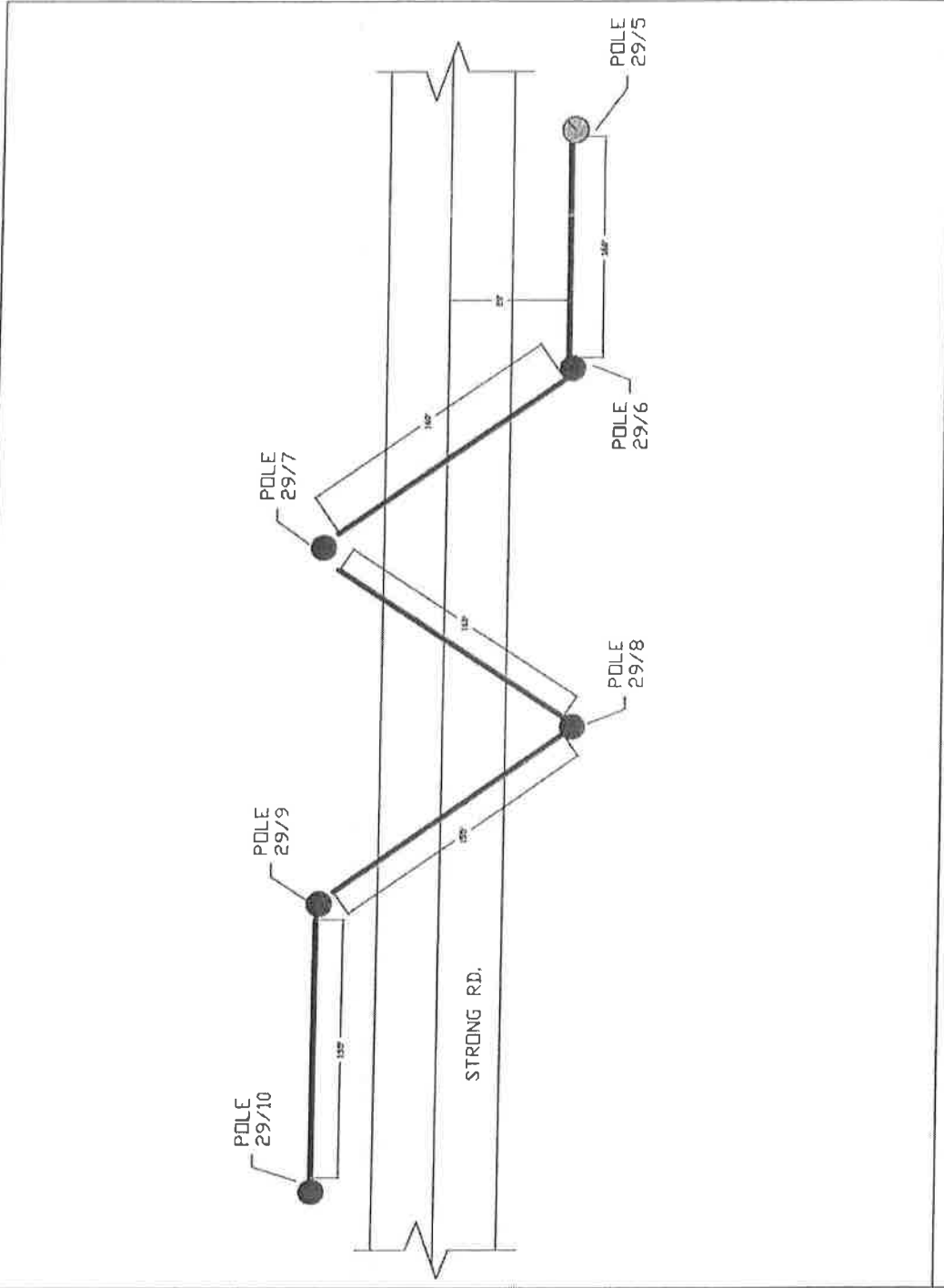

PURPOSE AND DESCRIPTION:
 EVERSOURCE IS REQUESTING PERMISSION TO INSTALL (5) 40' UTILITY POLES, TO BE NUMBERED 29/6 THRU 29/10 WITH ANCHORING ALONG STRONG RD EXTENDING FACILITIES FROM OUR LAST EXISTING POLE (29/5) TO 20 STRONG RD. POLES WILL ALTERNATE THE ROAD APPROXIMATELY 20' FROM THE ROAD CENTERLINE AND SPACED APPROXIMATELY 150'-160' APART.

May 3, 2024

Verne Leach, Select Board Chair
Town of Peru
3 East Main Road
Suite #107
Peru, MA 01235

Dear Select Board Chair,

Under the provisions of Chapter 166 of General Laws and any additions thereto or amendments thereof, a public hearing IS NECESSARY on the attached petitions. Please schedule a public hearing at your earliest convenience.

A signed original of the Order should be returned to EVERSOURCE with your approval, disapproval or comments noted thereon. A signed original should also be retained for your files. Recording of the petition is not necessary. When adopted, please forward the Orders to the Town Clerk for recording.

Town Clerk, please return signed and recorded orders to:

Joanne Fox
Eversource
333 West St.
Pittsfield, MA 01201

NOTE: On questions pertaining to this order, please call Jesse Martin at 413-585-1735.

Sincerely,

Joanne Fox

Joanne Fox
District Representative

Enclosures

Ref: 16741834-16747339

EVERSOURCE

PETITION FOR SOLELY OWNED POLE AND WIRE LOCATIONS

By the Select Board of Peru, Massachusetts

NSTAR ELECTRIC COMPANY DBA EVERSOURCE requests permission to relocate and/or install poles, wires, cables and fixtures, including the necessary sustaining and protecting fixtures along and across the following public way:

Location – Strong Road, Peru. Install five (5) solely owned poles:

Eversource is requesting permission to install five (5) forty-foot utility poles to be numbered 29/6 thru 29/10 with anchoring along Strong Road, extending facilities from our last existing pole 29/5 to 20 Strong Road. The poles will alternate the road approximately twenty feet from the road centerline and spaced approximately one hundred fifty to one hundred sixty (150-160) feet apart.

Reason – To extend facilities and provide power to homeowners.

Wherefore it prays that after due notice and hearing as provided by law, let it be granted a location for and permission to construct and maintain a pole, wires and cables, together with such sustaining and protecting fixtures as they may find necessary, said pole to be erected substantially in accordance with the plan filed herewith and made a part hereof marked **16741834-16747339**.

Also for permission to lay and maintain underground laterals, cables and wires in the above or intersecting public ways for the purpose of making connections with such poles and buildings as it may desire for distributing purposes.

Your petitioners agree to reserve space for one crossarm at a suitable point on each of said poles for the fire and police telephone signal wires belonging to the municipality and used by it exclusively for municipal purposes.

EVERSOURCE, By: Jesse Martin
Jesse Martin
Field Engineering Designer

Dated this 3rd day of May, 2024

TOWN COPY